

APPROXIMATING AREAS

We know how to compute the area of geometric shapes such as squares, rectangles, and trapezoids. Computing the areas of irregular shapes can be very difficult. However, we can approximate these areas using simpler shapes.

Warm Up

- (1) What is the formula for the area of a triangle? Draw a picture and prove this formula.

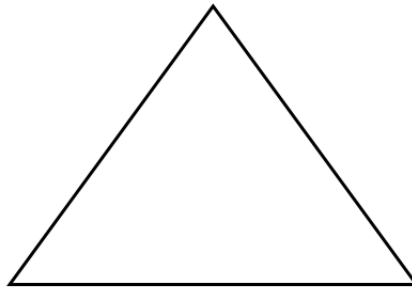

- (2) What is the formula for the area of a trapezoid? Draw a picture and prove this formula.

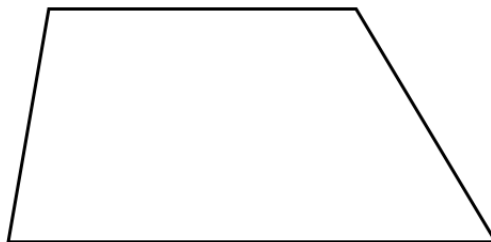

Approximating the Area of a Circle**Problem 1.**

- (1) Give the definition of π in terms of a circle's radius and circumference.
- (2) Suppose we divide a circle with radius r into many slices and arrange these slices into a shape similar to a parallelogram, as shown in the picture below.

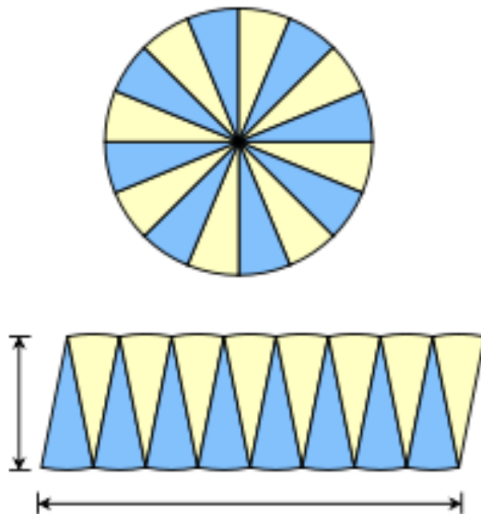

- (a) What is the relationship between the area of the circle and the area of the “parallelogram”?
- (b) Assuming we divided the circle into a lot of slices, approximate the following:
- The height of the parallelogram in terms of r .

(ii) The base of the parallelogram in terms of r .

(iii) Using the above, express the area of the circle in terms of r .

Problem 2. In the upcoming exercises, we will be exploring an alternative method of finding the area of a circle by using inscribed and circumscribed polygons.

(1) Using a circumscribed square:

(a) Approximate the area of the circle of radius r by finding the area of the circumscribed square.

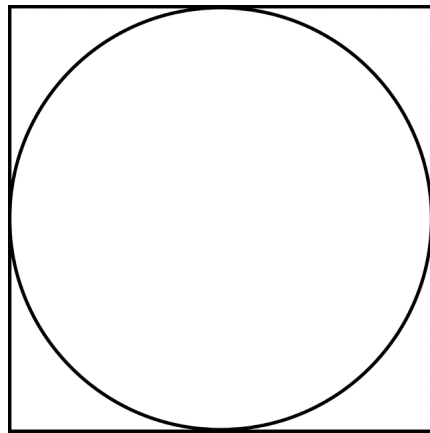

(b) Compare the exact area of the circle to the approximated area above. Is the approximated area an overestimate or an underestimate?

(2) Using an inscribed square:

(a) Approximate the area of the circle of radius r by finding the area of the inscribed square.

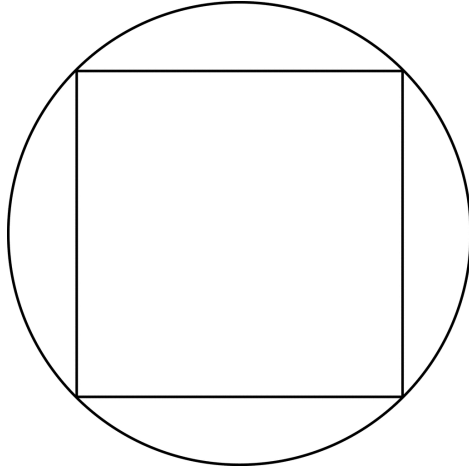

(i) What is the length of each side of the square?

(ii) What is the area of the square?

(b) Compare the exact area of the circle to the approximated area above. Is the approximated area an overestimate or an underestimate?

(3) Using a circumscribed hexagon:

(a) Approximate the area of the circle of radius r by finding the area of the circumscribed hexagon.

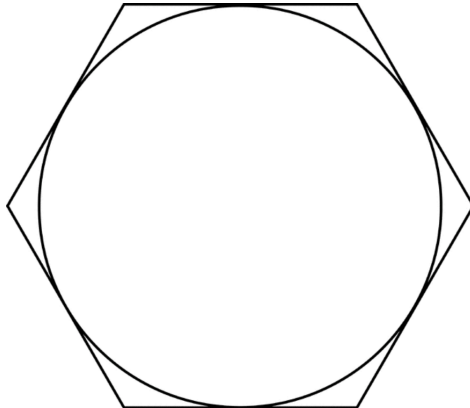

- (i) Divide the hexagon into 6 triangles by connecting the center of the circle to each vertex.
- (ii) Explain why each triangle is equilateral.

(iii) What is the height of each triangle?

(iv) Given the height of the triangle, the Pythagorean theorem and the fact that the triangle is equilateral, what is the base of each triangle?

(v) What is the area of each triangle?

(vi) What is area of the hexagon?

(b) Compare the exact area of the circle the the approximated area above. Is the approximated area an overestimate or an underestimate?

(4) Using a inscribed hexagon:

(a) Approximate the area of the circle of radius r by finding the area of the inscribed hexagon.

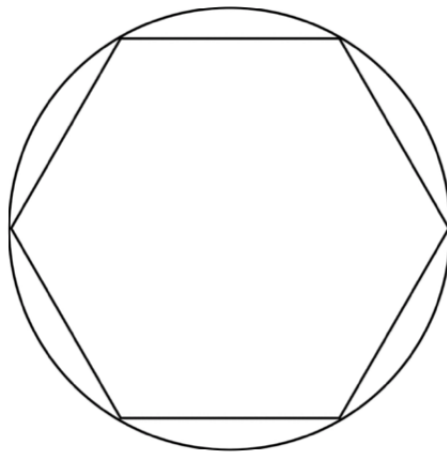

(i) Divide the hexagon into 6 equilateral triangles by connecting the center of the circle to each vertex.

(ii) What is the base of each triangle?

(iii) Given the base of the triangle, the Pythagorean theorem and the fact that the triangle is equilateral, what is the height of each triangle?

(iv) What is the area of each triangle?

(v) What is area of the hexagon?

(b) Compare the exact area of the circle the the approximated area above. Is the approximated area an overestimate or an underestimate?

Approximating Area Under a Graph

How can we approximate the area under a graph? A useful way to approach this question is to use rectangles to approximate the area under the graph. To do this, we divide the length of shape into segments and create rectangles which stand on the x-axis and touch our graph. We then calculate the area of each rectangle and sum up the areas we obtain.

Problem 3. Use 3 rectangles to approximate the area under the graph below.

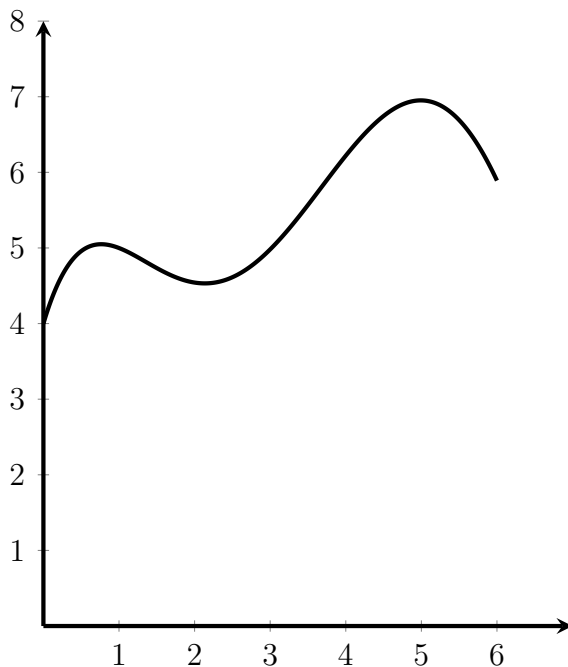

- (1) Divide the interval $[0, 6]$ on the x-axis into 3 rectangles by using vertical bars.
- (2) Connect the vertical bars by a horizontal bar which passes through the graph at center of the bar.
- (3) Find the area of the rectangles and the approximation for the graph.

Area Under the Curve and Distance Traveled**Problem 4. Traveling at constant velocity.**

Suppose a car is traveling at a constant speed v miles per hour for t hours.

- (1) Draw a graph on the axis below representing the above scenario.

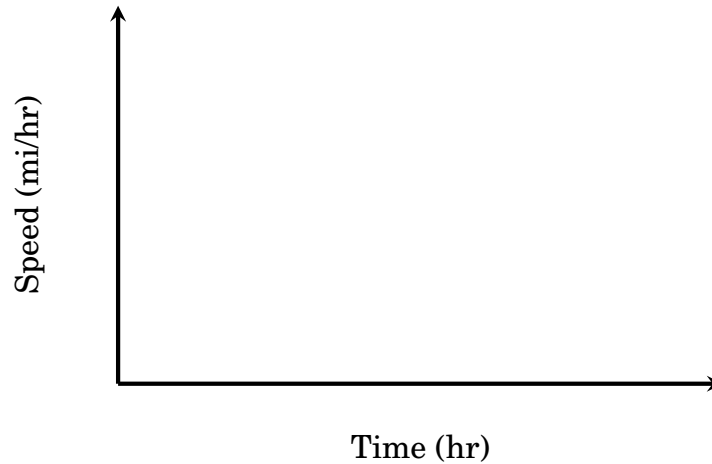

- (2) What is the distance the car traveled?

- (3) What is the area under the graph?

- (4) How is the area under the graph related to the distance the car traveled?

- (5) Give an equation for the distance traveled d in terms of the velocity v and the time traveled t .

Problem 5. Traveling at constant acceleration.

Suppose a car is initially stopped and then accelerates at a mi/hr² for t hours.

- (1) Draw a graph on the axis below representing the above scenario.

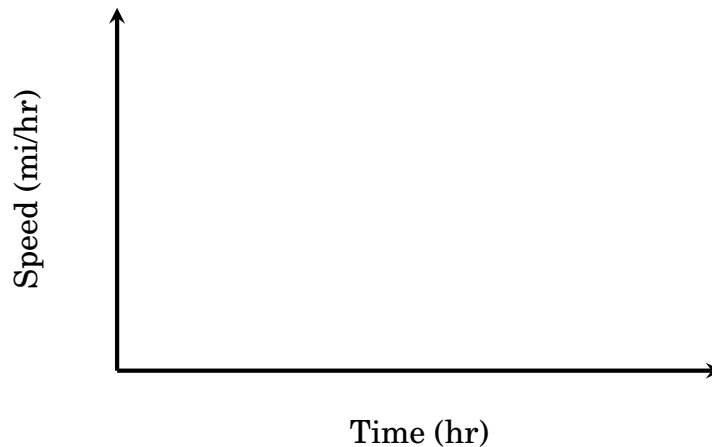

As you may have discovered in Problem 4, the distance traveled can be found by calculating the area under the graph.

- (2) Give an equation for the distance traveled d in terms of the acceleration a and the time traveled t .

Problem 6. (Challenge) Traveling at constant acceleration with initial velocity.

Suppose a car is initially traveling at v_0 miles per hour and then accelerates at a mi/hr² for t hours.

- (1) Give an equation for the distance traveled d in terms of the initial velocity v_0 , the acceleration a , and the time traveled t . You may want to use a graph to help you.

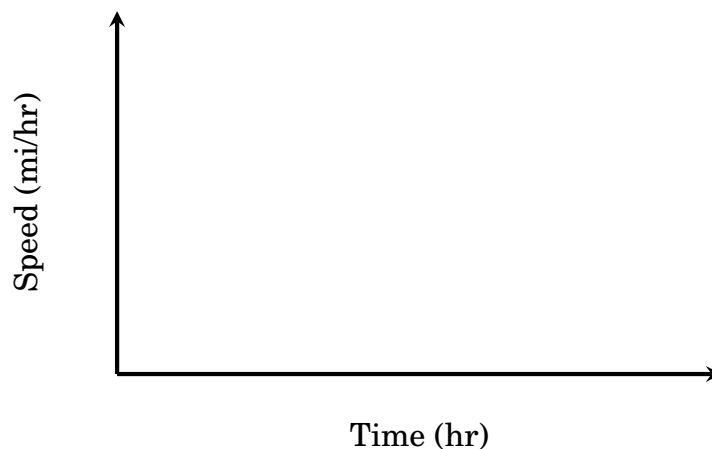

Problem 7. Consider the graph below which shows the speed of a plane during a 5 hour trip.

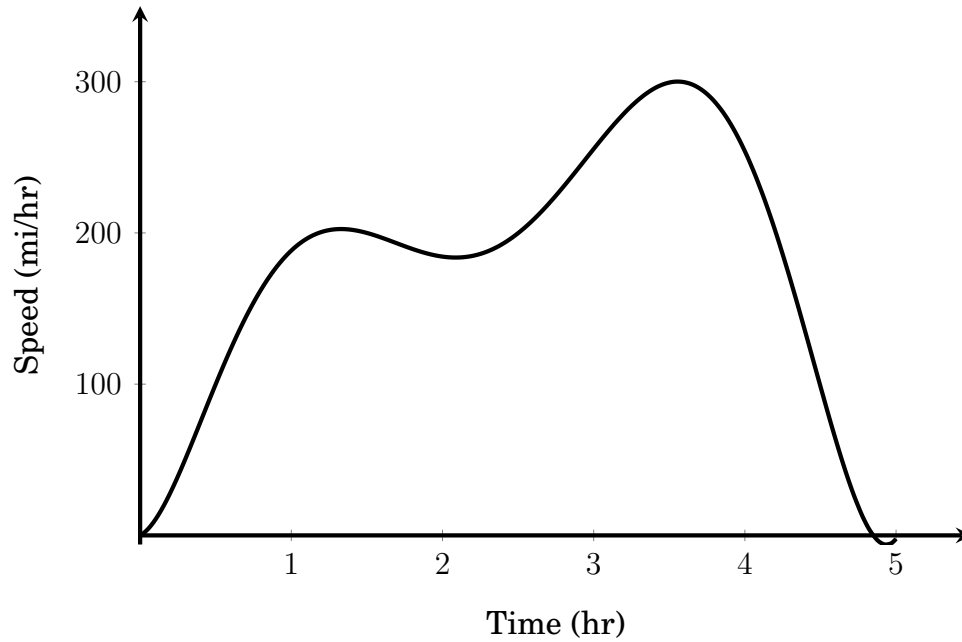

Approximately how far did the plane travel?

Problem 8. Suppose Dani went for a run from her home to the library. However, during her run, she realized she forgot her library card so she ran back home to grab it. She then continued to run towards the library. The graph below shows her running speed throughout her trip.

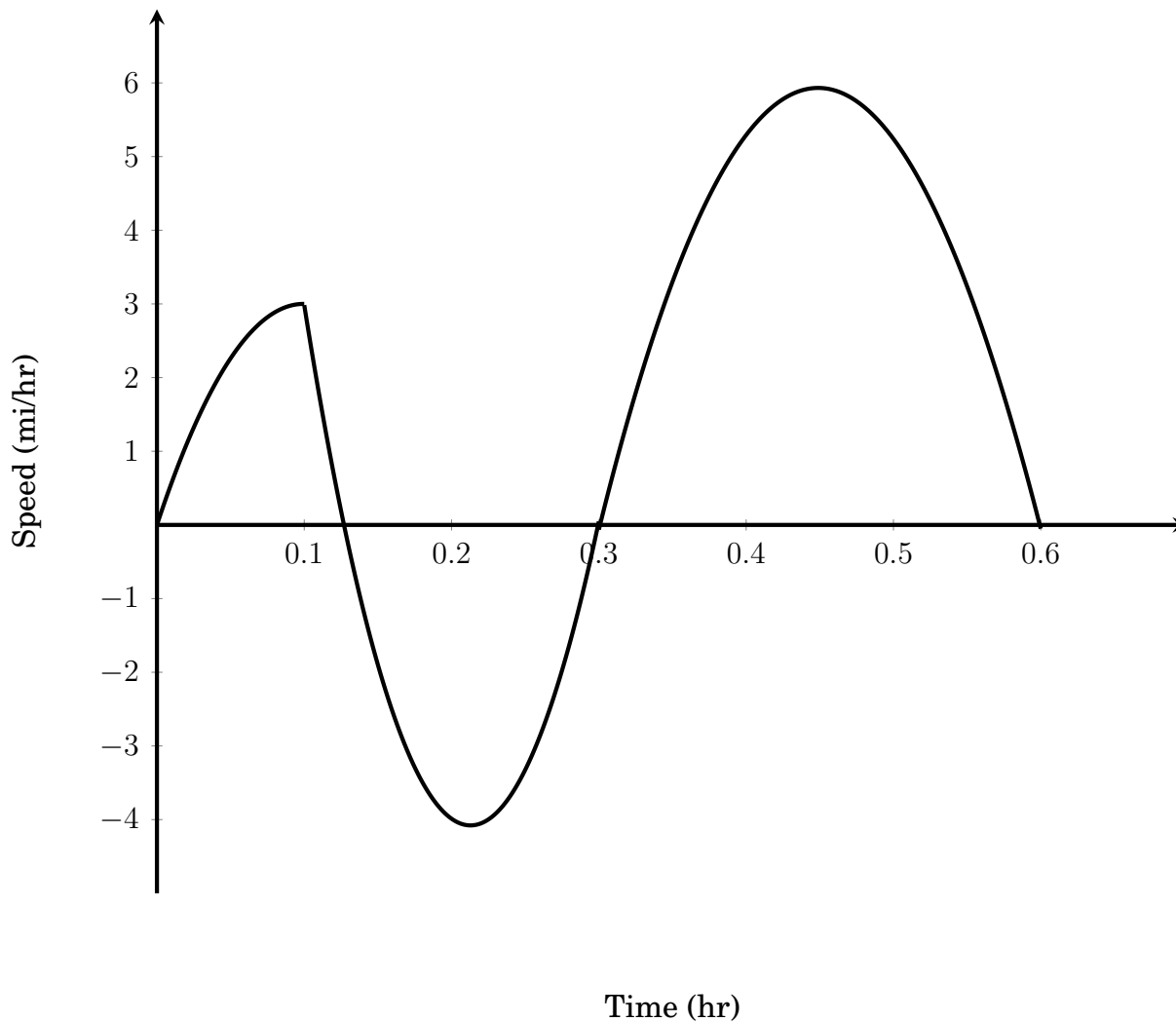

- (1) Notice that the graph above shows a section where her running speed was negative. What does this section correspond to?

(2) How many miles did Dani Run?

(3) Assuming that Dani ran in a straight line to the library, how far is the library from her house?

(4) What is the difference between questions 2 and 3? How did you calculate them differently?

Math Kangaroo Problems

- (1) Each of the pictures below shows a square with a side of 1 and shaded circles. In which picture is the shaded area the greatest? Justify your answer.

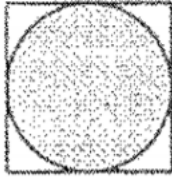

Picture 1

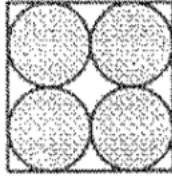

Picture 2

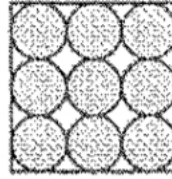

Picture 3

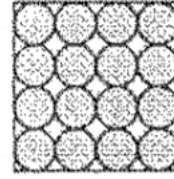

Picture 4

- (2) What is the ratio of the area of the shaded triangle to the area of the regular hexagon?

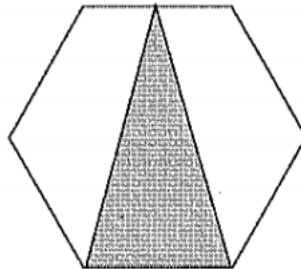

- (3) Find the area of the shaded portion with respect to x .

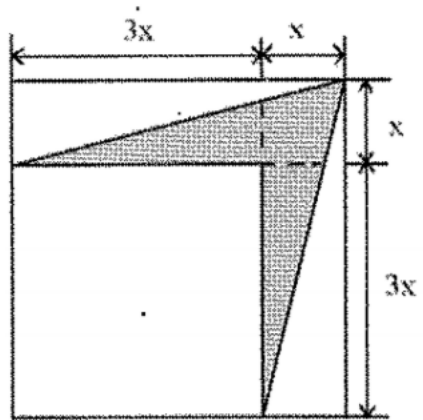

- (4) The diagram shows a shaded quadrilateral $KLMN$ drawn on a grid. Each cell of the grid has sides of length 2 cm. What is the area of $KLMN$?

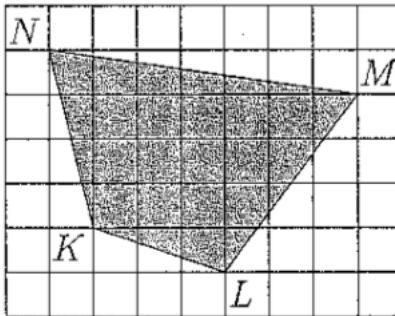

- (5) The large triangle shown in the picture was divided into 36 small equilateral triangles, each with an area of 1. Find the area of triangle ABC .

